

STAINLESS STEEL FIRE RATED HINGE

UK-S 8000 SERIES

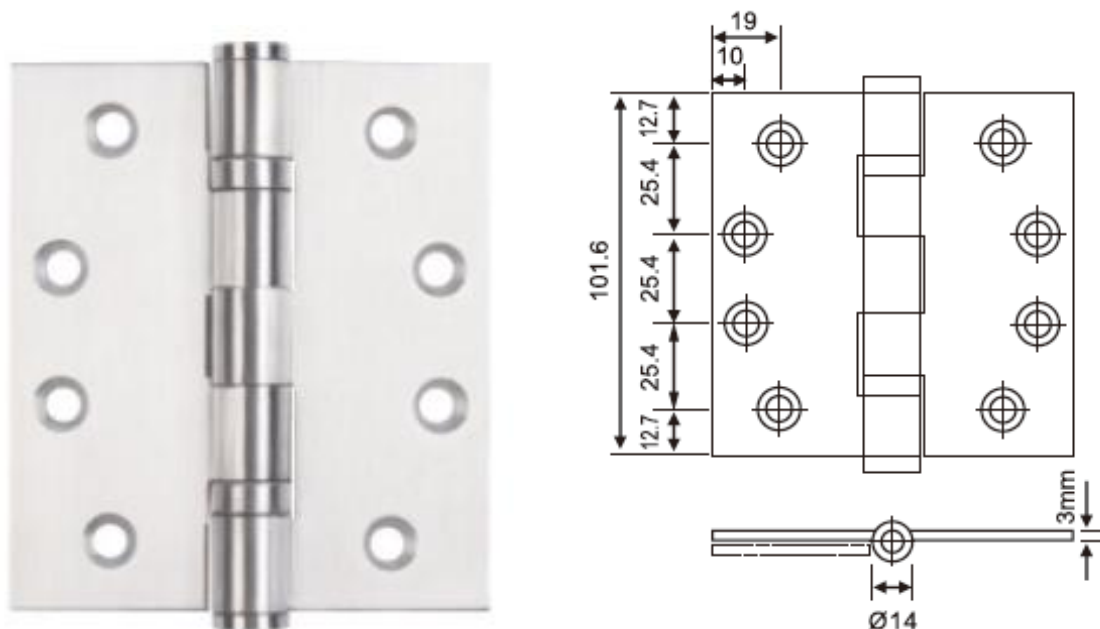

PRODUCT CLASSIFICATION

4 7 6 1 1 4 0 13

Model No.	Size (L*W*T inch*inch*mm)	Type	Finishes	Material
UK-S 8101 SS201	4*3*3	2BB Butt Hinge	Satin	SUS201
UK-S 8201 SS201	4*3.5*3	2BB Butt Hinge	Satin	SUS201
UK-S 8301 SS201	4*4*3	2BB Butt Hinge	Satin	SUS201
UK-S 8401 SS304	4*3*3	2BB Butt Hinge	Satin	SUS304
UK-S 8501 SS304	4*3.5*3	2BB Butt Hinge	Satin	SUS304
UK-S 8601 SS304	4*4*3	2BB Butt Hinge	Satin	SUS304
UK-S 8701 SS316	4*3*3	2BB Butt Hinge	Satin	SUS316
UK-S 8801 SS316	4*3.5*.3	2BB Butt Hinge	Satin	SUS316
UK-S 8901 SS316	4*4*3	2BB Butt Hinge	Satin	SUS316

STAINLESS STEEL FIRE RATED HINGE

UK-S 8000 SERIES



Intended uses:	On fire/smoke compartmentation doors fitted with door closing devices (to enable such doors to close reliably and thus achieve self-closing in the event of fire)	
Requirement / Characteristic	Requirement clauses in this European Standard	Results
• Self Closing	5.1 Initial friction torque	Less than 4,0 Nm with door mass 120kg
	5.2 Static load - Load deformation	Pass with displacement under load: - Lateral < 4 mm; - Vertical < 2 mm And a residual displacement after unloading: - Lateral < 0,2 mm; - Vertical < 0,3 mm
	5.2 Static load - Overload	Pass
	5.3 Shear strength	Pass No breakage and cracking Lateral deformation under loading < 3 mm Additional lateral and vertical displacement after unloading < 1 mm
	5.6 Hinges for use on fire-resistant and/or smoke control doors	Grade 1: Suitable for use on fire/smoke resistant door assemblies
• Durability	5.4 Durability	Pass (200,000 cycles) Maximum wear: - Lateral < 0,2 mm - Vertical < 1 mm Maximum frictional torque: - After 20 cycles and completion of 200,000 cycles, less than 4,0 Nm.
	5.5 Corrosion resistance	Grade 4, Neutral Salt Spray (NSS) – 240 hours
• Dangerous substances	Note 1 of ZA 1	No dangerous substances declared for this product/intended use