

ADVANCED HOTEL LOCKS

1800 Mortise Stainless Steel - Fire Rated

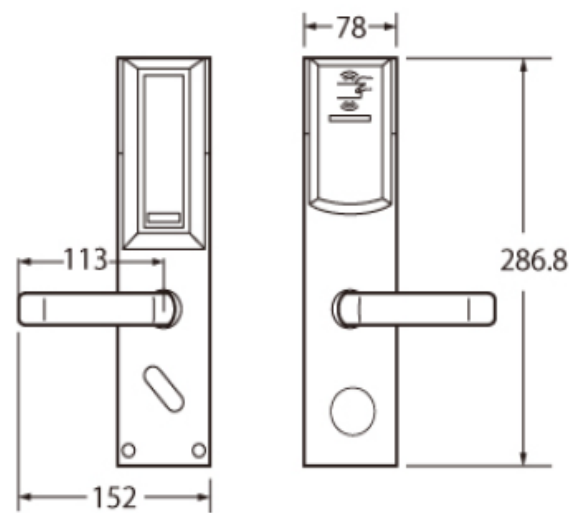

Back View

Front View

All dimensions are in mm

FEATURES

- Cast steel unified structure
- High damage resistance
- Anti-pick latch design and anti-friction latch alarming system enable duple safety.
- Card Type: Mifare Card
- Working Voltage: DC 6V (4 x AA battery)
- Static Consumption: 100uA
- Dynamic Consumption: <2000mA
- Battery Life: Approximately 15,000 times of normal operations
- Low Voltage Alarm: Three “beep” sounds alarming while the voltage is lower than 4.5V
- Unlocking Record: Audit trail records the latest 828 lock openings including mechanical override.
- Mechanical key: Override ensures prompt emergency opening when electric key is invalid while the lock is in the status of double-lock.
- Applicable for door thickness: 38 – 70mm