

PUSH BAR EXIT DEVICE 506 2-point Lock

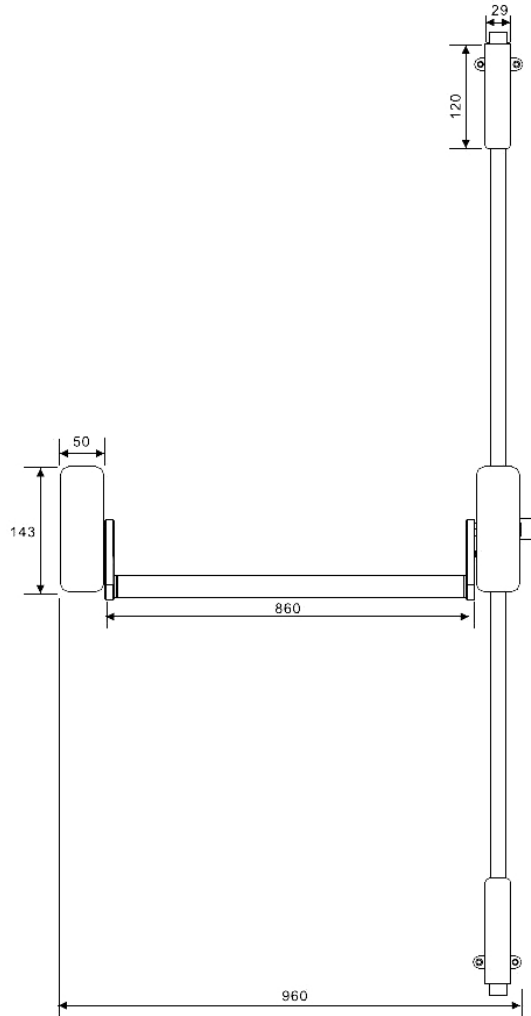
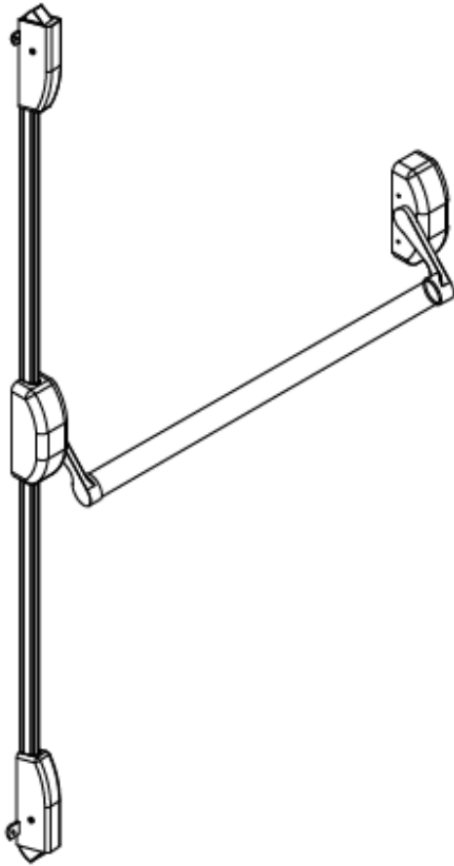

PRODUCT CLASSIFICATION

3 7 6 B 1 4 2 2 A A

500 SERIES

1. CE mark, Fire Rated
2. EN1125 and EN1634 approved
3. None handed
4. Pullman latch and lateral latch design
5. Modular design, more than 4 point locks are available.
6. Material: Stainless steel or steel powder coating
7. Difference finish is available

FEATURE

Lock Point	2
Push Bar	1,000mm length
Door Style	Single and Double Door
Max. Door Weight	200 kg
Dogging Device	N/A
Security Anti-thrust Latch	N/A
Door Width	Up to 1,500mm
Door Height	2,133mm
1Door Thickness	50mm